

DESIGNED FOR AN OE-QUALITY REPAIR

PRECISION ENGINEERED AND TESTED TO INTEGRATE WITH EVAP SYSTEM

PV704 / SKU: 474527

Canister Purge Valve
GM Cars & SUVs
(2021-12)
VIO: 4M

OE-Matching Connectors

Ensures exact-fit connection
to engine wire harness

Improved Durability

Design improvement
over the OE helps
reduce wear, preventing
future leaks

OE-Matching Fitting

Quick disconnect
fittings ensure exact fit
and fast installation

Hose Included

All-new hose for a quick
and reliable repair

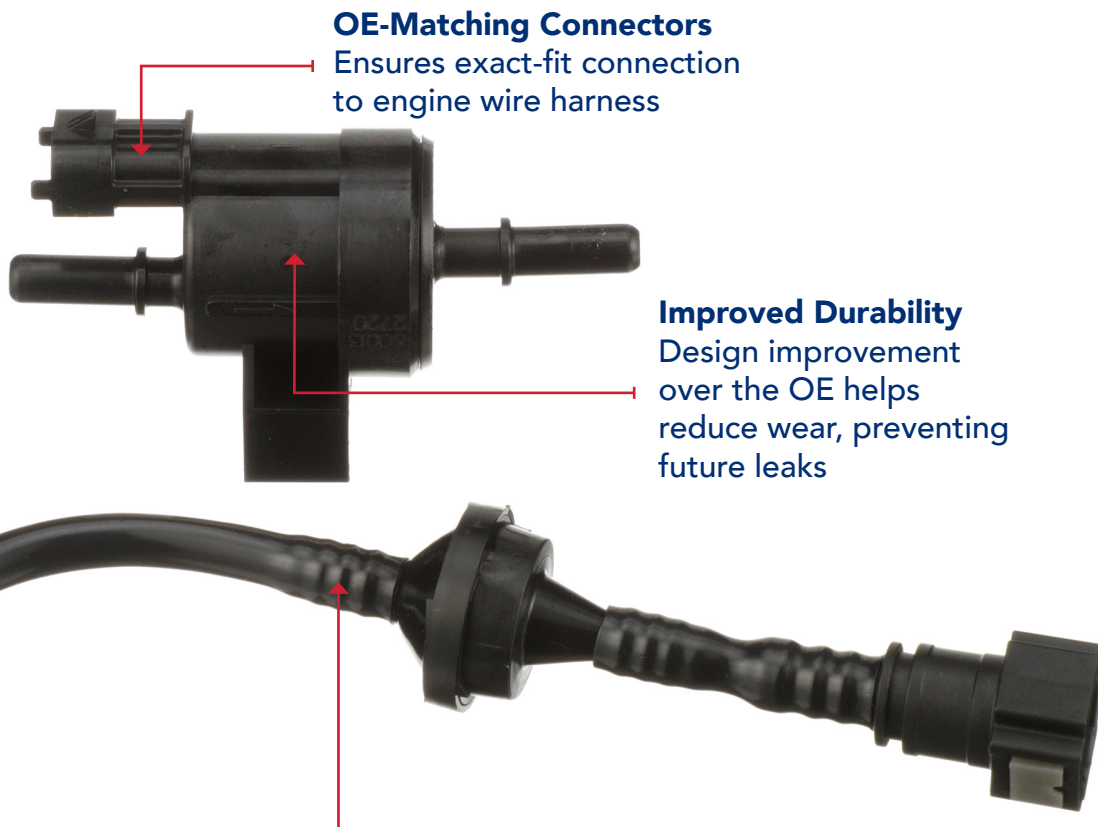

IMPROVES ON LIMITATIONS IN THE OE DESIGN

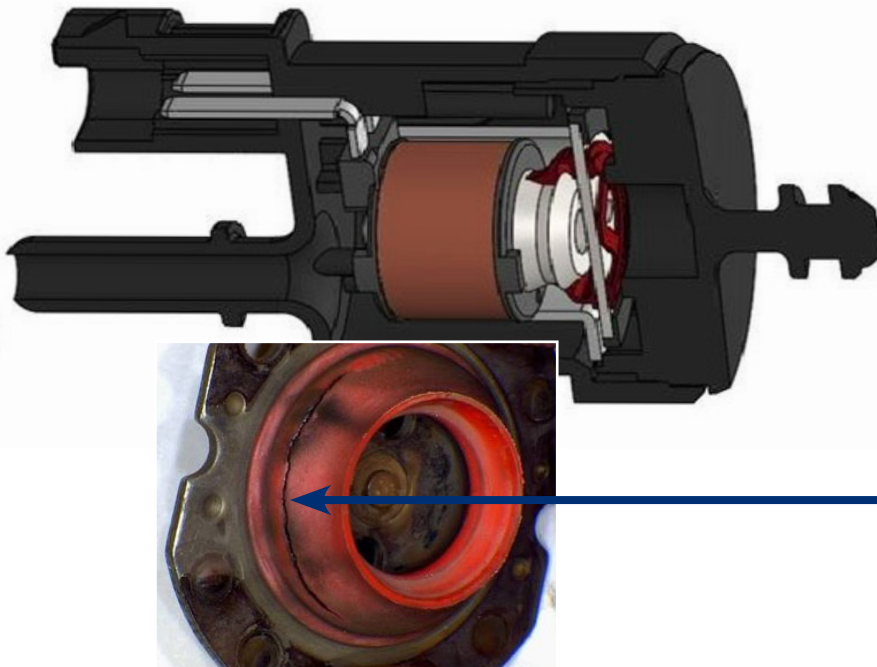

OE PROBLEM

The plunger assembly cracks, causing an EVAP system leak.

Source: GM Technical Service Bulletin 18029

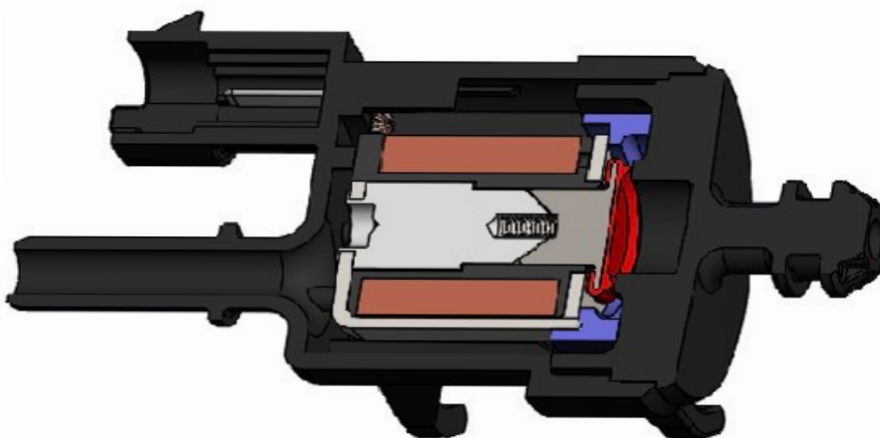

THE DURALAST® DIFFERENCE

Improved geometry keeps the plunger in alignment, reducing wear on the seal. The result is a longer-lasting component.

PV704 / SKU: 474527
(MADE IN THE USA)

Exclusively at



ORDER TODAY!

CALL YOUR COMMERCIAL SALES MANAGER
OR VISIT AUTOZONEPRO.COM TO LEARN MORE